

European Organisation for Technical Approvals
Europäische Organisation für Technische Zulassungen
Organisation Européenne pour l'Agrément Technique

ETAG 015

Edition September 2002

**GUIDELINE FOR EUROPEAN TECHNICAL APPROVAL OF
THREE-DIMENSIONAL NAILING PLATES**

**EOTA - Kunstlaan 40 Avenue des Arts
B - 1040 BRUSSELS**

Table of contents

Foreword

Background	5
Reference documents	5
Updating conditions	5

Section One: Introduction

1 Preliminaries	7
1.1 Legal basis	7
1.2 Status of ETAG	7
2 Scope	9
2.1 Scope	9
2.2 Use categories, product families, kits and systems	12
2.3 Assumptions	12
3 Terminology	13
3.1 Common terminology and abbreviations	13
3.2 Terminology and abbreviations specific to this ETAG	13

Section Two: Guidance for the assessment of the fitness for use

General notes

(a) Applicability of the ETAG	14
(b) General layout of this section	14
(c) Levels or classes or minimum requirements	14
(d) Working life (durability) and serviceability	15
(e) Fitness for the intended use	15
4 Requirements for works, and their relationship to the characteristics of the three-dimensional nailing plates	16
4.0 General	16
4.1 Mechanical resistance and stability	17
4.1.1 <i>Strength</i>	18
4.1.2 <i>Stiffness</i>	18
4.1.3 <i>Ductility in cyclic testing1</i>	18
4.2 Safety in case of fire	18
4.2.1 <i>Reaction to fire</i>	18
4.2.2 <i>Fire resistance</i>	18
4.3 Hygiene, health and the environment	18
4.3.1 <i>Release of dangerous substances</i>	19
4.4 Safety in use	19
4.5 Protection against noise	20
4.6 Energy economy and heat retention	20
4.7 Aspects of durability, serviceability and identification	20
4.7.1 <i>Durability and serviceability</i>	20
4.7.2 <i>Identification of the product</i>	21
5 Methods of verification	22
5.0 General	22
5.1 Mechanical resistance and stability	23

5.1.0	General	23
5.1.1	Calculation	24
5.1.2	Calculation assisted by testing	25
5.1.3	Testing	27
5.2	Safety in case of fire	31
5.3	Hygiene, health and the environment	31
5.3.1	Release of dangerous substances	31
5.4	Safety in use	32
5.5	Protection against noise	32
5.6	Energy economy and heat retention	32
5.7	Aspects of durability serviceability and identification	32
5.7.1	Durability and serviceability	32
5.7.2	Methods of identification	33
6	Assessing and judging of the fitness of products for an intended use	34
6.0	General	34
6.1	Mechanical resistance and stability	34
6.1.1	Strength	34
6.1.2	Stiffness	35
6.1.3	Ductility in cyclic testing	35
6.2	Safety in case of fire	35
6.3	Hygiene, health and the environment	35
6.3.1	Release of dangerous substances	35
6.4	Safety in use	36
6.5	Protection against noise	36
6.6	Energy economy and heat retention	36
6.7	Aspects of durability, serviceability and identification	36
6.7.1	Durability, corrosion and deterioration	36
6.7.2	Serviceability	36
6.7.3	Identification of the product	36
7	Assumptions and recommendations under which the fitness for use of the three-dimensional nailing plates is assessed	38
7.0	General	38
7.1	Design of the works	38
7.2	Packaging, transport and storage	38
7.3	Execution of works	38
7.4	Maintenance and repair	38

Section Three: Attestation and Evaluation of Conformity (AC)

8	Attestation and Evaluation of conformity	39
8.1	EC Decision	39
8.2	Responsibilities	39
8.2.1	Tasks for the manufacturer	39
8.2.2	Tasks for the manufacturer or the Approved Body	39
8.2.3	Tasks for the Approved Body	39
8.3	Documentation	39
8.4	CE marking and information	39

Section Four: ETA content

9	The ETA content	43
9.1	The ETA content	43
9.1.1	Model ETA	43

9.1.2	<i>Performance</i>	43
9.2	Additional information.....	44

Annex A Common terminology and abbreviations (definitions, clarifications)

Annex B List of documents

FOREWORD

Background

This Guideline has been drawn up by the EOTA Working Group 06.03/01 (three-dimensional nailing plates) in response to the Mandate awarded to EOTA (Construct 99/339, rev 1, dated 28.05.99).

The Working Group consisted of members from the following EU countries:

Denmark, Germany and the United Kingdom.

The Guideline covers three-dimensional metal plate connections including timber-to-timber joist hangers, but excluding punched metal plate timber fasteners in two dimensions in Mandate 112 for 'Structural timber products and ancillaries' and joist hangers in Mandate 116 for 'Masonry and related products'.

The Guideline defines relevant performance requirements, the verification methods used to examine the various aspects of performance, the assessment criteria used to judge the performance for the intended use and the presumed conditions for the design and execution of three-dimensional nailing plates in the works.

The general assessment approach of the Guideline is based on relevant existing knowledge and testing experience.

Where relevant, national technical specifications have been discussed and taken into account in developing appropriate test and calculation methods for assessing the three-dimensional nailing plates.

Reference documents

Reference documents are referred to within the body of the ETAG and are subject to the specific conditions mentioned therein.

The **list of reference documents** (mentioning the year of issue) for this ETAG is given in Annex B. When additional parts for this ETAG are written afterwards, they may comprise modifications to the list of reference documents applicable to that part.

Updating conditions

The edition of a reference document given in this list is that which has been adopted by EOTA for its specific use.

When a new edition becomes available, this supersedes the edition mentioned in the list, only when EOTA has verified or re-established (possibly with appropriate linkage) its compatibility with the Guideline.

EOTA Technical Reports go into detail in some aspects and as such are not part of the ETAG but express the common understanding of existing knowledge and experience of the EOTA bodies at that moment. When knowledge and experience is developing, especially through approval work, these reports can be amended and supplemented.

EOTA Comprehension Documents permanently take on board all useful information on the general understanding of this ETAG as developed when delivering ETAs in consensus by the EOTA members. Readers and users of this ETAG are advised to check the current status of these documents with an EOTA member.

EOTA may need to make alterations/corrections to the ETAG during its life. These changes will be incorporated into the official version on the EOTA website www.eota.be and the actions catalogued and dated in the associated **Progress File**.

Readers and users of this ETAG are advised to check the current status of the content of this document with that on the EOTA website. The front cover will indicate if and when amendment has taken place.

SECTION ONE: INTRODUCTION

1 PRELIMINARIES

1.1 LEGAL BASIS

This ETAG has been established in compliance with the provisions of the Council Directive 89/106/EEC (CPD) and has been established taking into account the following steps:

- the final mandate issued by the EC: 28/05/1999
- the final mandate issued by the EFTA: 28/05/1999
- adoption of the Guideline by the Executive Commission of EOTA: 13/06/2002
- opinion of the Standing Committee on Construction: 10/09/02
- endorsement by the EC: 24/09/02

This document is published by the Member States in their official language or languages according to Art. 11.3 of the CPD.

No existing ETAG is superseded.

1.2 STATUS OF ETAG

1.2.1 An ETA is one of the two types of technical specifications in the sense of the 89/106/EEC Construction Products Directive. This means that Member States shall presume that the approved three-dimensional nailing plates are fit for their intended use, ie they enable works in which they are employed to satisfy the Essential Requirements during an economically-reasonable working life, provided that:

- the works are properly designed and built
- the conformity of the products with the ETA has been properly attested.

1.2.2 This ETAG is a basis for ETAs, ie a basis for technical assessment of the fitness for use of a three-dimensional nailing plate for an intended use. An ETAG is not in itself a technical specification in the sense of the CPD.

This ETAG expresses the common understanding of the approval bodies, acting together within EOTA, of the provisions of the Construction Products Directive 89/106/EEC and of the Interpretative Documents in relation to the three-dimensional nailing plates and uses concerned, and is written within the framework of a mandate given by the Commission and the EFTA Secretariat, after consulting the Standing Committee on Construction.

1.2.3 When accepted by the European Commission after consultation with the Standing Committee on Construction, this **ETAG is binding** for the issuing of ETAs for the three-dimensional nailing plates for the defined intended uses.

The application and satisfaction of the provisions of an ETAG (examinations, tests and evaluation methods) leads to an ETA and a presumption of fitness of a three-dimensional nailing plate for the defined use only through an evaluation and approval process and decision, followed by the corresponding attestation of conformity. This distinguishes an ETAG from a harmonized European standard which is the direct basis for attestation of conformity.

Where appropriate, three-dimensional nailing plates which are outside of the precise scope of this ETAG may be considered through the approved procedure without Guidelines according to Art. 9.2 of the CPD.

The requirements in this ETAG are set out in terms of objectives and of relevant actions to be taken into account. It specifies values and characteristics, the conformity with which gives the presumption that the requirements set out are satisfied wherever the state of the art permits and after having been confirmed as appropriate for the particular product by the ETA.

2 SCOPE

2.1 SCOPE

This Guideline covers preformed three-dimensional metal nailing plates with specified fasteners for connections in loadbearing timber structures and for fixing timber structures or wood-based structural members to their support.

The specified fasteners include nails, screws, bolts and dowels.

Examples of three-dimensional nailing plates are given in Figure 1 and possible configurations are given in Figure 2. For other types not represented by these examples, to ensure a consistent approach to the assessment, the consensus procedure described in clause 2.3 shall be followed.

The ETAG does not cover:

- products covered by Mandate M112 to CEN for ‘Structural timber products and ancillaries’.
- joist hangers covered by Mandate M116 to CEN for ‘Masonry and related products’ (as ‘ancillary components’).
- use of three-dimensional nailing plates in pile foundations. Such use is defined in the Mandate addressed to EOTA, but there is no history of use of these products for this purpose.
- products not covered by EC Decision 96/603/EC, amended by EC Decision 2000/605/EC (reaction to fire class A1 without testing).

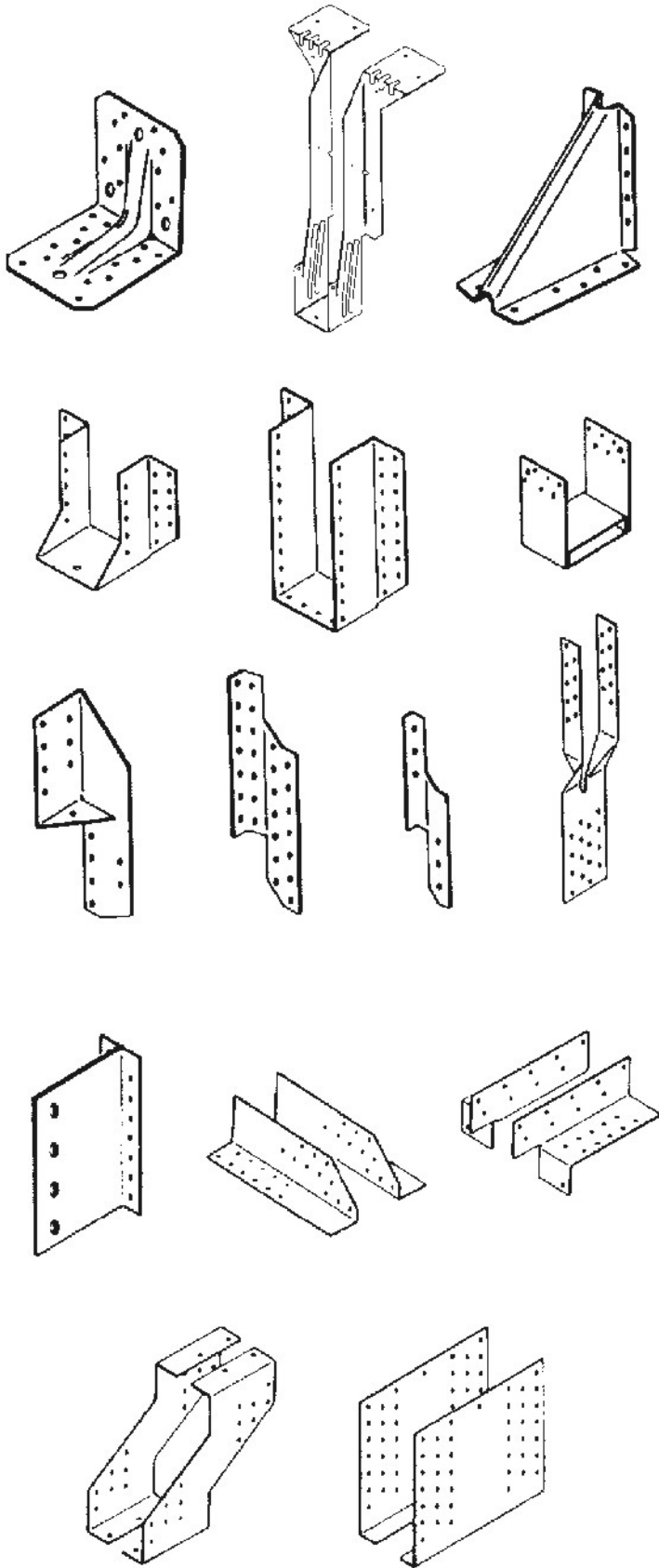
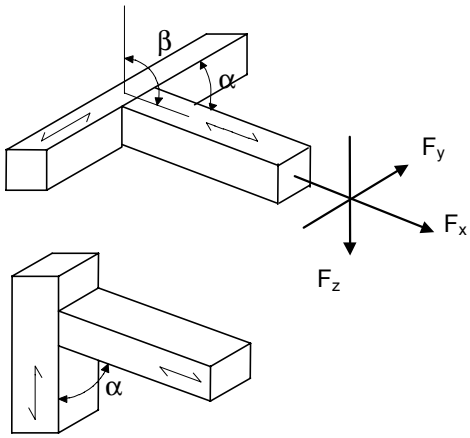
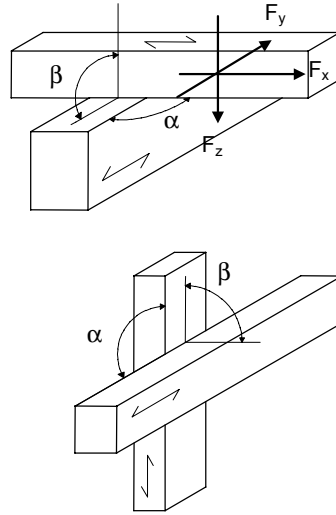

Figure 1 Examples of three-dimensional nailing plates



Arrangement and loading of timber members with end-grain to side-grain



Arrangement and loading of timber members with side-grain to side-grain

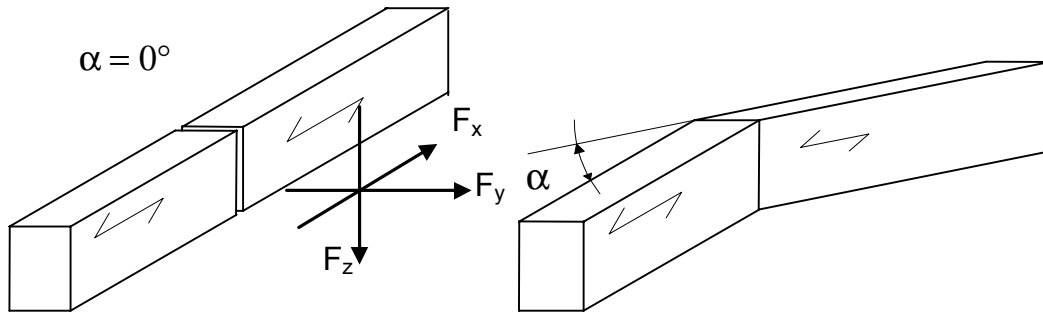

Arrangement and loading of timber members with end-grain to end-grain

Figure 2 Possible configurations of timber members

2.2 USE CATEGORIES, PRODUCT FAMILIES, KITS AND SYSTEMS

The ETAs issued may cover either of the following:

The three-dimensional nailing plate and the fasteners. The fasteners may be produced by subcontractors. Both the three-dimensional nailing plates and the fasteners are marketed and supplied by the ETA holder who takes full responsibility for the products.

or

The three-dimensional nailing plate only, but giving a specification for the fasteners by trade name, performance criteria, dimensional criteria or reference to a standard.

2.3 ASSUMPTIONS

The state of the art does not enable the development, within a reasonable time, of full and detailed verification methods and corresponding technical criteria/guidance for acceptance for some particular aspects or products. This ETAG contains assumptions taking into account the state of the art and makes provisions for appropriate, additional **case-by-case approaches** when examining ETA applications, within the general framework of the ETAG and under the CPD consensus procedure between EOTA members.

The guidance remains valid for other cases which do not deviate significantly. The general approach of the ETAG remains valid but the provisions then need to be used case by case in an appropriate way. This use of the ETAG is the responsibility of the ETA body which receives the special application, and subject to consensus within EOTA. Experience in this respect is collected, after endorsement in EOTA-TB, in the ETAG-Format-Comprehension document.

The main assumptions made in this ETAG are that the design of the structural connection is in accordance with the relevant recommendations of Eurocode 5, or an appropriate structural timber design code, particularly in relation to the duration of load, the effects of reversal of load from long- and medium-term actions and alternating between tension and compression actions in the members.

3 TERMINOLOGY

3.1 COMMON TERMINOLOGY AND ABBREVIATIONS

See Annex A.

3.2 TERMINOLOGY AND ABBREVIATIONS SPECIFIC TO THIS ETAG

3.2.1 Unless otherwise stated the terminology used in Eurocode 5 applies.

3.2.2 The modified characteristic load-carrying capacity $X_{k,mod}$ is the 5% fractile in the distribution of the load-carrying capacity for the stated relevant load duration and service class. It is equal to $k_{mod}X_k$ as given in Eurocode 5.

3.2.3 **Wane** — Original rounded sapwood surface of a log, without bark, on any face or edge of sawn timber.

3.2.4 **Square-edged timber** — Sawn timber of rectangular cross section, with wane, if permitted, not exceeding a specified amount.

3.2.5 **Connection** — joint

Note: The Mandate and Eurocode 5 make reference to 'joints', accordingly this Guideline uses 'joints' rather than the equivalent term 'connections'.

SECTION TWO: GUIDANCE FOR THE ASSESSMENT OF THE FITNESS FOR USE

General notes

(a) APPLICABILITY OF THE ETAG

This ETAG provides guidance on the assessment of a family of three-dimensional nailing plates and their intended uses. It is the manufacturer or producer who defines the three-dimensional nailing plates for which he is seeking an ETA and how it is to be used in the works, and consequently the scale of the assessment.

Therefore, it is possible that for some three-dimensional nailing plates, which are fairly conventional, only some of the tests and corresponding criteria are sufficient to establish fitness for use. In other cases, eg special or innovative three-dimensional nailing plates or materials, or where there is a range of uses, the whole package of tests and assessment may be applicable.

(b) GENERAL LAYOUT OF THIS SECTION

The assessment of the fitness of three-dimensional nailing plates with regard to their fitness for intended use in construction works is a process with three main steps:

- Chapter 4 clarifies **the specific requirements for the works** relevant to the three-dimensional nailing plates and uses concerned, beginning with the Essential Requirements for works (CPD Art. 11.2) and then listing the corresponding relevant characteristics of three-dimensional nailing plates.
- Chapter 5 extends the list in Chapter 4 into more precise definitions and the **methods available to verify** product characteristics and to indicate how the requirements and the relevant product characteristics are described. This is done by test procedures, methods of calculation and of proof, etc.
- Chapter 6 provides guidance on **the assessing and judging methods** to confirm fitness for the intended use of the three-dimensional nailing plates.
- Chapter 7 **assumptions and recommendations** are only relevant in as far as they concern the basis upon which the assessment of the three-dimensional nailing plates is made concerning their fitness for the intended use.

(c) LEVELS OR CLASSES OR MINIMUM REQUIREMENTS, RELATED TO THE ESSENTIAL REQUIREMENTS AND TO THE PRODUCT PERFORMANCE (see ID Clause 1.2 and EC Guidance Paper E).

According to the CPD, 'Classes' in this ETAG refer only to mandatory levels or classes laid down in the EC-mandate.

This ETAG indicates, however, the compulsory way of expressing relevant performance characteristics for the three-dimensional nailing plates.

If, for some uses, at least one Member state has no regulations, a manufacturer always has the right to opt out of one or more of them, in which case the ETA will state 'no performance determined' against that aspect, except for those properties for which, when no determination has been made, the three-dimensional nailing plates no longer fall under the scope of the ETAG; such cases shall be indicated in the ETAG.

(d) WORKING LIFE (DURABILITY) AND SERVICEABILITY

The provisions, test and assessment methods in this Guideline or referred to, have been written, based upon the assumed intended working life of the three-dimensional nailing plate for the intended use of 50 years, provided that the three-dimensional nailing plate is subject to appropriate use and maintenance (cf. ch 7). These provisions are based upon the current state of the art and the available knowledge and experience.

An 'assumed intended working life' means that it is expected that, when an assessment following the ETAG-provisions is made, and when this working life has elapsed, the real working life may be, in normal use conditions, considerably longer without major degradation affecting the essential requirements.

The indications given as to the working life of a three-dimensional nailing plate cannot be interpreted as a guarantee given by the producer or the approval body. They should only be regarded as a means for the specifiers to choose the appropriate criteria for three-dimensional nailing plates in relation to the expected, economically reasonable working life of the works (based upon ID, par 5.2.2).

(e) FITNESS FOR THE INTENDED USE

According to the CPD it has to be understood that within the terms of this ETAG, products shall 'have such characteristics that the works in which they are to be incorporated, assembled, applied or installed, can, if properly designed and built, satisfy the Essential Requirements' (CPD, Art. 2.1).

Hence, the three-dimensional nailing plates must be suitable for use in construction works which (as a whole and in their separate parts) are fit for their intended use, account being taken of economy, and in order to satisfy the essential requirements. Such requirements must, subject to normal maintenance, be satisfied for an economically reasonable working life. The requirements generally concern actions which are foreseeable (CPD, Annex I, preamble).

4 REQUIREMENTS FOR WORKS, AND THEIR RELATIONSHIP TO THE CHARACTERISTICS OF THE THREE-DIMENSIONAL NAILING PLATES

4.0 GENERAL

This chapter sets out the aspects of performance to be examined to satisfy the relevant Essential Requirements, by:

- expressing in more detail, within the scope of the ETAG, the Relevant Essential Requirements of the CPD in the Interpretative Documents and in the mandate, for works or parts of the works, taking into account the actions to be considered, as well as the expected durability and serviceability of the works.
- applying them to the scope of the ETAG (three-dimensional nailing plates and where appropriate their constituents, components and intended uses), and providing a list of relevant three-dimensional nailing plates characteristics and other applicable properties.

When a product characteristic or other applicable property is specific to one of the Essential Requirements, it is dealt with in the appropriate place. If, however, the characteristic or property is relevant to more than one Essential Requirement, it is addressed under the most important one with cross-reference to the other(s). This is especially important where a manufacturer claims 'No performance determined' for a characteristic or property under one Essential Requirement and it is critical for the assessing and judging under another Essential Requirement. Similarly, characteristics or properties which have a bearing on durability assessments may be dealt with under ER 1 to ER 6, with reference under 4.7. Where there is a characteristic which only relates to durability, this is dealt with in 4.7.

This chapter also takes into account further requirements, if any (eg resulting from other EC Directives) and identifies aspects of serviceability including specifying characteristics needed to identify the three-dimensional nailing plates (cf. ETA-format, par II.2).

The relevant Essential Requirements, the relevant paragraphs of the corresponding IDs and the related requirements to product performance are indicated in Table 4.1.

Table 4.1

ER	Corresponding ID paragraph for works	Corresponding ID paragraph for product performance	Product characteristics from the Mandate	ETAG paragraph on product performance
1	4.2 Provisions concerning works or part of them	4.3.1 Related characteristics 4.3.2 Performances of products (see Appendix – Table 2 <i>Timber products for structural use</i>)	Mechanical resistance (eg strength, stiffness ..., as relevant)	4.1 Mechanical resistance and stability
2	4.2.3.3.1 Limitation of the generation of fire and smoke within the room	4.3.1.1 Products subject to reaction to fire requirements		4.2 Safety in case of fire: 4.2.1 reaction to fire 4.2.2 resistance to fire
3	3.3.1.1 Indoor environment – Air quality	3.3.1.1.3.2a Building materials	Release of dangerous substances ⁽¹⁾	4.3 Hygiene, health and the environment
4	NOT RELEVANT			4.4 Safety in use
5	NOT RELEVANT			4.5 Protection against noise
6	NOT RELEVANT			4.6 Energy economy and heat retention
(2)			Durability against corrosion, as relevant	4.7 Aspects of durability, serviceability and identification

(1) In particular, those dangerous substances defined in Council Directive 76/769/EEC as amended.

(2) Aspects of durability, serviceability and identification.

4.1 MECHANICAL RESISTANCE AND STABILITY

The Essential Requirement laid down in the Council Directive 89/106/EEC is:

The Construction Works must be designed and built in such a way that the loadings that are liable to act on it during its construction and use will not lead to any of the following:

- *collapse of the whole or part of the work*
- *major deformations to an inadmissible degree*
- *damage to other parts of the works or to fittings or installed equipment as a result of major deformation of the loadbearing construction*
- *damage by an event to an extent disproportionate to the original cause*

The following aspects of performance are relevant to this Essential Requirement for three-dimensional nailing plates:

Actions are imposed on a structure during its life, for example, arising from the action of wind, snow, thermal expansion, moisture induced deformation, self weight of structure, etc. Hence the strength and stiffness of the product shall be considered in relation to permanent, variable and accidental actions.

The range of values for actions and other influences that need to be considered shall be in accordance with laws, regulations and administrative provisions, applicable for the location when the product is incorporated in the works.

4.1.1 Strength

The strength of the product shall be sufficient to withstand the actions acting on the joint. Consideration shall be given to duration of load and service class.

The following actions may apply:

tension
shear
compression
bending
torsion
translation between members
rotation between members
or a combination of these actions.

4.1.2 Stiffness

The stiffness of the product shall be sufficient to keep the major deformations to an admissible degree and not cause damage to the works and other constructions. Consideration shall be given to duration of load and service class.

4.1.3 Ductility in cyclic testing

In seismic zones where dissipative structural behaviour is assumed in design, the joints shall have an appropriate ductility in cyclic testing.

4.2 SAFETY IN CASE OF FIRE

The Essential Requirement laid down in the Council Directive 89/106/EEC is:

The construction works must be designed and built in such a way that in the event of an outbreak of fire:

- *the loadbearing capacity of the construction can be assumed for a specific period of time*
- *the generation and spread of fire and smoke within the works are limited*
- *the spread of fire to neighbouring construction works is limited*
- *occupants can leave the works or be rescued by other means*
- *the safety of rescue teams is taken into consideration.*

The following aspects of performance are relevant to this Essential Requirement for three-dimensional nailing plates:

4.2.1 Reaction to fire

The requirements for reaction to fire for three-dimensional nailing plates must be in accordance with laws, regulations and administrative provisions, applicable to these products in their intended end use application.

4.2.2 Fire resistance

Performance in relation to fire resistance would be determined for the complete structural element with any associated finishes, therefore there are no aspects of performance relevant to this aspect of this Essential Requirement for three-dimensional nailing plates.

4.3 HYGIENE, HEALTH AND THE ENVIRONMENT

The Essential Requirement laid down in the Council Directive 89/106/EEC is:

The construction work must be designed and built in such a way that it will not be a threat to the hygiene or health of the occupants or neighbours, in particular as a result of any of the following:

- *the giving-off of toxic gas*
- *the presence of dangerous particles or gases in the air*
- *the emission of dangerous radiation*
- *pollution or poisoning of the water or soil*
- *faulty elimination of waste water, smoke, solid or liquid wastes*
- *the presence of damp in parts of the works or on surfaces within the works.*

The following aspects of performance are relevant to this Essential Requirement for three-dimensional nailing plates.

4.3.1 Release of dangerous substances

The three-dimensional nailing plate must be such that, when installed according to the appropriate provisions of the Member States, it allows for the satisfaction of the ER3 of the CPD as expressed by the national provisions of the Member States and in particular does not cause harmful emission of toxic gases, dangerous particles or radiation to the indoor environment nor contamination of the outdoor environment (air, soil and water).

4.4 SAFETY IN USE

The Essential Requirement laid down in the Council Directive 89/106/EEC is:

The construction work must be designed and built in such a way that it does not present unacceptable risks of accidents in service or in operation such as slipping, falling, collision, burns, electrocution, injury from explosion.

There are no aspects of performance relevant to this Essential Requirement for three-dimensional nailing plates.

4.5 PROTECTION AGAINST NOISE

The Essential Requirement laid down in the Council Directive 89/106/EEC is:

The construction works must be designed and built in such a way that noise perceived by the occupants or people nearby is kept down to a level that will not threaten their health and will allow them to sleep, rest and work in satisfactory conditions.

There are no aspects of performance relevant to this Essential Requirement for three-dimensional nailing plates.

4.6 ENERGY ECONOMY AND HEAT RETENTION

The Essential Requirement laid down in the Council Directive 89/106/EEC is:

The construction works and its heating, cooling and ventilation installations must be designed and built in such a way that the amount of energy required in use shall be low, having regard to the climatic conditions of the location and occupants.

There are no aspects of performance relevant to this Essential Requirement for three-dimensional nailing plates.

4.7 ASPECTS OF DURABILITY, SERVICEABILITY AND IDENTIFICATION

4.7.1 Durability and serviceability

4.7.1.1 Resistance to corrosion and deterioration

The requirements considered in the following paragraphs are related to the Essential Requirements, but not to any one requirement in particular. As a consequence, failure to meet these requirements means that one, or more than one, of the Essential Requirements may no longer be met.

Three-dimensional nailing plates, and components and their possible finishes shall be resistant to deterioration caused by physical or chemical agents to prevent reduction of mechanical properties during their intended life.

An assessment will be made of the risks of deterioration arising from any proposed preservative treatment for the timbers used with the product, or with any corrosive timber species proposed for use.

The three-dimensional nailing plates and all associated ancillary components, shall not be adversely affected by deterioration, distortion, deformation due to:

Physical agents

Variations in temperature/humidity
Differences in temperature and/or relative humidity.

Chemical agents

Water, carbon dioxide, oxygen (possible corrosion) and other normal chemical hazards likely to come into contact. Loss of function arises from corrosion from weather and industrial, urban or marine environments or a combination of these.

4.7.1.2 Dimensional stability

The effects of changes in moisture content and the consequent dimensional changes on the structural elements being joined, due to varying moisture content, shall be evaluated by the determination of the strength and stiffness of the joints.

4.7.2 Identification of the product

The products shall be precisely defined by reference to physical characteristics, such as:

- material
- strength properties
- surface treatment
- dimensions.

5 METHODS OF VERIFICATION

5.0 GENERAL

This chapter refers to the verification methods used to determine the various aspects of performance of the products in relation to the requirements for the works (calculations, tests, engineering knowledge, site experience, etc) as set out in Chapter 4.

When Eurocodes are quoted in this ETAG as the methods for the verification of certain product characteristics, their application in this ETAG, as well as in the subsequent ETAs issued according to this ETAG, shall be in accordance with the principles laid down in the EC Guidance Paper on the use of Eurocodes in harmonised European technical specifications.

The relevant Essential Requirements, the related requirements to product performances (as given in Chapter 4), the corresponding product characteristics to be assessed and the corresponding verification methods are indicated in Table 5.1.

Not all the requirements in the following section will be relevant to every product. A 'No performance determined' option is possible in some cases and it will be for the manufacturer to decide, taking account of their intended market and which options they wish to have assessed.

It is possible to use existing data from recognised laboratories with expertise in testing of timber structures and having an adequate quality system, which includes the calibration of testing equipment. The possibility exists to use existing data in accordance with the EOTA Guidance Document No 004 on 'The provision of data for assessment leading to ETA'. It is the responsibility of the EOTA Technical Board to ensure that the intentions of the tests mentioned in this chapter are fulfilled.

Based on existing data and/or the claimed performance of the three-dimensional nailing plate by the manufacturer, the approval body may decide that not all investigations mentioned in this chapter are necessary and the Approval Body has the discretion to develop a suitable programme for the assessment of three-dimensional nailing plate taking account of the intended use and the claimed performance.

Table 5.1

ER	Corresponding ID paragraph for product performance	Product characteristics	ETAG paragraph on verification method
1	4.3.1 Related characteristics 4.3.2 Performances of products (see Appendix – Table 2 <i>Timber products for structural use</i>)	Joint strength Joint stiffness Joint ductility in cyclic testing	5.1 Mechanical resistance and stability
2	4.3.1.1 Products subject to reaction to fire requirements	Reaction to fire	5.2 Safety in case of fire
3	3.3.1.1.3.2a Building materials	Dangerous substances	5.3.1 Release of dangerous substances
4	NOT RELEVANT		
5	NOT RELEVANT		
6	NOT RELEVANT		
(1)		Durability against corrosion	5.7 Aspects of durability, serviceability and maintenance

(1) Aspects of durability, serviceability and identification

5.1 MECHANICAL RESISTANCE AND STABILITY

5.1.0 General

Three-dimensional nailing plate joints may be designed to resist forces with specified positions and/or moments in several directions or a combination of these.

The mechanical resistance and stability of three-dimensional nailing plates can be verified using:

- Calculation
- Calculation assisted by testing
- Testing.

The force and moment capacity shall be determined for deformations of the timber members similar to those of the structures in which they are intended for use.

The manufacturers shall specify either the strength class according to EN 338 : 1995 or the species, grade and surface finish of the timber or structural timber composite.

The possible existence of wane shall be considered. If wane is allowed, the maximum extent of wane allowed in the specification shall be used in the calculations or testing.

The support and restraint conditions shall be those specified by the manufacturer.

The support and restraint conditions for the members are critical to the performance and hence the characteristic loads of the three-dimensional nailing plate, and shall reflect the declared intended use.

The manufacturer shall specify any assumptions regarding preparation of timber members, eg pre-drilled holes, tolerance on hole diameter and any special installation/ maintenance provisions, eg retightening of bolts.

The mechanical resistance and stability shall be determined taking into consideration the gaps between the timber members that can occur in practice. For side grain to side grain connections it can normally be assumed that the timber members are brought close together without any gap. For end-grain and for end-grain to side-grain connections the maximum permitted size of the gap shall be considered and, in no case, shall be smaller than 3 mm between mating faces (timber-timber or timber-three-dimensional nailing plate). To avoid the possibility of failure by a zipper effect, failure of the fasteners should not take place by head tear-off.

In seismic zones, a dissipative structural behaviour may be assumed if an appropriate low cycle fatigue behaviour of the joints is verified by cyclic testing according with EN 12512 : 2001, as required by prEN 1998-1:2001.

5.1.1 Calculation

5.1.1.1 General

Calculations can be used as documentation if the three-dimensional nail plate is of a ductile material and if either of the following conditions is fulfilled:

- The static behaviour of the joint is ductile and if the components of the joint have a ductile force-deformation behaviour.
- If the static behaviour of the mechanical fasteners (nails or screws) is brittle, eg pull out, then the force distribution over these shall be determined statically or based on a conservative assumption.

Note: Three-dimensional nailing plates of steel in accordance with EN 10088-2, : 1995 EN 10142 : 2000, or EN 10147 : 2000, with a 0.2% proof strength $\leq 350 \text{ Nmm}^{-2}$ may be regarded as ductile.

The calculations shall be carried out in accordance with Eurocodes 3 and 5.

The calculations shall be based on the characteristic material properties for the appropriate load duration and service class, calculated in accordance with Eurocode 5 using the factor k_{mod} .

Where relevant, the deformations of the connection shall be calculated as described in Eurocode 5 and in accordance with load levels given in EN 26891 : 1991.

The values of the instantaneous slip modulus K_{ser} given in Eurocode 5 may be used in the calculations.

Examples of methods which may be used for calculations are given in EOTA Technical Report 'Principles for the static calculation of connections made with three-dimensional nailing plates, with examples'. A worked example is given in EOTA Technical Report 'Worked example calculation of characteristic load-carrying capacities of 90° angle bracket with a rib'.

5.1.1.2 Properties of materials and components

The properties of the materials and the components of the three-dimensional nailing plate joints shall be specified preferably by reference to the relevant ENs.

For the steel parts, the specified yield stresses and the ultimate stresses shall be documented.

If the static model provides for withdrawal of the nails or screws from the wood, tensile failure in the steel cross-section shall be excluded (head tear-off or tear-off in the area of thread). It shall be documented by testing (see clause 5.1.3.1.4) that this requirement is satisfied.

For the nails, screws, dowels or bolts subjected to lateral load or to axial load the load-carrying capacities and the stiffnesses shall be determined either from Eurocode 5 or from tests (see clause 5.1.3.1.3).

5.1.1.3 Static models

5.1.1.3.1 The calculation of the nailing plate joints shall take into account the internal forces and the deformations of the timber members, which come from the global analysis of the structure. The deformation of the connected timber members and the components in the three-dimensional nailing plate connection shall be assumed compatible with those from the global analysis of the structure.

The analysis of a three-dimensional nailing plate joint shall take into account the static behaviour of all elements, which constitute the joint.

5.1.1.3.2 Equilibrium shall be fulfilled in any part of the joint. If used, the finite element analysis shall comprise the three-dimensional nailing plate, the fasteners, the connected members and the supports, if any. All eccentricities shall be considered.

5.1.1.3.3 It shall be documented that the internal forces in the three-dimensional nailing plate joints are less than the capacities.

5.1.1.3.4 The limited deformation capacity of the components in the three-dimensional nailing plate joints shall be considered.

For threaded nails and screws subjected to a lateral force and having a penetration depth $l > 9d$, where d is the diameter of the nail or screw as defined in Eurocode 5, an elastic-plastic behaviour may be assumed.

For threaded nails and screws subjected to an axial force a brittle failure shall be assumed.

Note: Axial loaded nails or screws with even a small difference in the axial deformation, should be assumed to have different axial force.

5.1.2 Calculation assisted by testing

5.1.2.1 General

5.1.1 applies.

Calculation assisted by testing comprises:

- verification of the static model
- determination of properties of the component by test as input data for the static model, eg the yielding moment of an embossed nailing plate section
- or combination of the above.

5.1.2.2 Scope of testing and calculations

- 5.1.2.2.1 The scope of the testing is to verify or calibrate a theoretical static model of the three-dimensional nailing plate joints or to derive properties where calculation is not practical or possible for particular properties.

The model shall reflect the actual static behaviour.

It can be assumed that the verification has been carried out if the theoretical static model — possibly with some efficiency factors — can describe the static behaviour of the three-dimensional nailing plate joints.

A static model for the ultimate load-carrying capacity of the joint can only be assumed to be verified, if the model for the load-carrying capacities of the connection components can predict the load carrying capacity of the joint.

- 5.1.2.2.2 The static model shall be verified for the type of forces in the joint and for the range of their position.

Note: The model should be verified for the range of eccentricities to be used in the calculations.

The verification shall make special consideration to the case of axial loaded nails or screws. From the verification tests it shall be possible to establish either the effective number of nails or screws or the effectiveness of the nails or screws.

- 5.1.2.2.3 For three-dimensional nailing plates with special cross-sections or varying cross-sections, eg pressed or deformed cross-sections, the bending capacity of the three-dimensional nailing plate cross-sections can be determined by testing (see 5.1.2.3.4).

5.1.2.3 Testing of properties

- 5.1.2.3.1 The requirements of section 5.1.3 apply.

- 5.1.2.3.2 Tests to determine the moisture content and density of the timber shall be carried out in accordance with the relevant test standards referenced in Eurocode 5 or in its supporting standards.

- 5.1.2.3.3 Tests to determine the relevant properties related to the steel components shall be carried out in accordance with the relevant test standards referenced in Eurocode 3 or in its supporting standards.

- 5.1.2.3.4 Testing of the bending capacity of three-dimensional nailing plates with special cross-section shall be carried out in a way that the bending of the three-dimensional nailing plate corresponds to the actual moment distribution of the three-dimensional nailing plate in the connection.

Note: The three-dimensional nailing plate may be clamped by bolts in the nail holes, and subjected to the force causing bending by a tension rod through a hole in the three-dimensional nailing plate, as shown in Figure 3.

By applying the force in the downward or upward direction, a bending moment can be applied to the three-dimensional nailing plate with tension or compression stresses in the deformed part of the cross-section as would occur in the actual connection.

By applying the force with one or a few eccentricities, a curve of the bending capacity of the flange of the three-dimensional nail plate can be determined. The plot of the bending capacity will consist of several straight lines determined from the tests with different eccentricity.

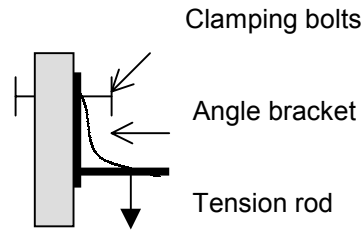

Figure 3 Example of test assembly

5.1.3 Testing

5.1.3.0 General

Testing for joint strength and stiffness shall be in accordance with EN 26891 : 1991 and testing for joint ductility in cyclic conditions shall be in accordance with EN 12512 : 2001.

The tests shall simulate the behaviour of the joint under practical conditions, and the loading, support and constraint conditions used in the test shall model those that apply in practice. As EN 26891 : 1991 is a general document, and due to the large variation in product type covered in this Guideline, it is not possible to set rules for each type. The general principles, which shall be adopted for the tests, are given below. Examples are given in EOTA Technical Report *Method of Testing Three-Dimensional Nailing Plates, with examples*. Further examples will be added as the need arises. These recommendations are based on the work of RILEM TC169-MTE who are continuing to develop test methods for three-dimensional nailing plates.

- (1) Determine cross-sections of primary and secondary members according to intended purpose and function and use these members in full scale during the tests.
- (2) Choose the test configuration to avoid failure due to effects outside the scope, eg failure due to tension perpendicular to the grain in the timber, bending failure of the secondary member, bearing failure at the loading points should not be present.
- (3) Choose the test configuration of the secondary member such that the deformation of the connection in the test zone reflects the intended use.
- (4) Avoid undue influence arising from the method of load application and member support which defies the intended purpose and function, eg loading should only be applied in the connected area if this covers the intended use.
- (5) Make sure that the load transmission principles within the arrangement are determinable, eg by using additional load cells to determine the exact load transferred by the connection; if relevant, the weight of the test equipment should be taken into account in the recorded data.
- (6) Measure the relative displacements between the members and take into consideration that undesirable influences are avoided by fixing the transducers at points away from the expected failure zone; place the transducers on either side of the specimen and average the results to take into account any distortion of the members.
- (7) Take into account that practical tolerances in the fit between the connected members can influence the load-carrying capacity of the connection, eg by arranging appropriate gaps between the members.
- (8) Assemble the test pieces with the timber at an equilibrium moisture content corresponding to $(20 \pm 2)^{\circ}\text{C}$ and $(85 \pm 5)\%$ relative humidity, condition the assembly to $(20 \pm 2)^{\circ}\text{C}$ and $(65 \pm 5)\%$ relative humidity until just before testing, and measure the

moisture content at the time of testing (other conditions should only be used if in line with the intended use of the connection).

- (9) When drying, shrinkage can significantly influence the load-carrying capacity or stiffness of the connection, therefore, special consideration shall be given to conditioning at fabrication and test.
- (10) Determine and record the relevant specifications of the materials, eg the quality or grade of the timber, the specifications and dimensions of the metalwork and other fasteners, and mention in the test report that the test results do not necessarily apply to other types of metalwork or timber.
- (11) A comprehensive record of load-deformation behaviour should be made for each variable of interest.

5.1.3.1 Materials and properties

The extent of testing depends on the type of documentation of load-bearing capacities:

- For calculations, the load-bearing capacities of the ancillary components are needed
- For calculation assisted by testing the capacities of the components of the joint are needed to verify the static model.
- For modification of the test results of the particular joint capacities the load-carrying capacities of the ancillary components and the strength properties of the three-dimensional nailing plate are needed.

5.1.3.1.1 Timber and wood-based materials

The timber shall be selected in accordance with either of the methods given in EN 28970 : 1991. The characteristic densities for species being taken from EN 338 : 1995.

Unless otherwise specified by the manufacturer the tests shall be carried out using European Whitewood (*Picea abies*).

Wood-based materials should be selected in a similar way, as for timber.

For a group of similar test pieces, separate planks shall be used for each test piece.

The members should be free from major defects in the area of the three-dimensional nailing plates. However, where wane is allowed, the test should be conducted with the maximum extent of wane (artificially produced by cutting if necessary) allowed by the specification, as described in clause 5.1.0.

The moisture content and density of the timber shall be determined as specified in ISO 3130 : 1975 and ISO 3131 : 1975, as appropriate.

5.1.3.1.2 Three-dimensional nailing plates

The relevant characteristic properties (eg ultimate tensile strength, yield stress elongation) of the metal used to manufacture the three-dimensional nailing plates, taken from the coil or strip used in manufacture shall be determined using standard test procedures (eg EN 10002-1 : 1990). These data are required to establish the extent to which the properties of the metal used in the fabrication of the samples for test differ from the minimum properties specified.

The test samples shall be representative of production and shall be drawn at random. Pre-production samples may be used where it is possible to demonstrate that the characteristics of performance are representative of products from the full production process.

Most three-dimensional nailing plates are produced in a range of sizes, the sizes of three-dimensional nailing plates to be used in the various tests should be selected in such a way that the strength and stiffness of the complete range may be obtained by interpolation provided the failure mechanism is the same.

5.1.3.1.3 Associated ancillary components

For the nails or the screws subjected to lateral load or to axial load, the load-carrying capacities and the stiffnesses shall be determined from the tests described in EN 1380 : 1999, EN 1382 : 1999, EN 1383 : 1999 and EN 26891. The tests shall be conducted with relevant timber species with characteristic density according to EN 28970 : 1991.

The ancillary components used in the tests shall be representative of production and shall be drawn at random.

5.1.3.1.4 Tensile capacity of nails or screws

The tensile capacity of the nail or screw (head tear-off or tear-off in the area of thread) shall be determined in conformity with Figure 4 of EN 1383 : 1999. Instead of the timber or wood-based panel, a steel panel shall be used supplied with a pre-drilled hole for the nail or screw. The diameter of the drill hole in the steel plate shall exceed the external diameter d_1 of the profiled part of the shaft of the nail, or the threaded part of the screw, by approximately 0.1 mm. The area of transition from profiled/threaded part to smooth part of shaft shall be located within the free length of testing and shall have a clear distance from the jaws of the testing equipment of at least $3 \cdot d_1$.

The rate of loading shall be chosen so that failure load (ultimate load) is reached within $10 \text{ s} \pm 5 \text{ s}$.

From the test results, the characteristic tensile capacity of the nail or screw shall be calculated in accordance with the principles of Eurocode 5.

Note: Test methods for connections made with nails and screws are specified in EN 1380 : 1999, EN 1382 : 1999 and EN 1383 : 1999. The tensile capacity (head tear-off and tear-off in the area of thread) of nails and screws is not covered by these standards.

5.1.3.1.5 The nails, screws, bolts and dowels shall be in accordance with the draft harmonised standard prEN 14592 *Timber Structures - Fasteners — Requirements*.

5.1.3.1.6 Where the ancillary component is already CE marked and tested in accordance with the test methods mentioned in clause 5.1.3.1.3 it is not necessary to repeat the tests. However, assessment still has to be carried out according to Chapter 6 of this Guideline to ensure that the ancillary component is fit for the intended use. Where the ancillary component is not CE marked the tests in Chapter 5 shall be carried out.

5.1.3.2 Test methods for joints

5.1.3.2.1 General

Generally, three-dimensional nailing plates are available in a range of sizes; some can also be used with a range of timber sizes and a range of fasteners/fastener sizes. In producing a test specification, consideration should be given to the three-dimensional nailing plate sizes, the fasteners and timber member combinations. For specified fasteners testing the largest and smallest three-dimensional nailing plates and only one or more of the intermediate sizes may be appropriate. Interpolation for intermediate sizes may be used to determine three-dimensional nailing plate load capacity, where other physical properties remain the same (eg material specifications, materials irregularities and material section properties). To confirm the assumed interpolation formula, tests may be necessary. To achieve test results that reflect the

load capacity of the three-dimensional nailing plate and not the timber strength, selecting the largest timber size for a range of three-dimensional nailing plate sizes may be appropriate.

The minimum number of specimens to determine the following values is:

Mean value : three specimens

Characteristic value: five specimens

The support and restraint conditions shall be those specified by the manufacturer.

5.1.3.2.2 Conditioning

Before the test pieces are assembled the timber shall be conditioned to an equilibrium moisture content corresponding to $20 \pm 2^\circ\text{C}$ and $85 \pm 5\%$ relative humidity and after assembly the test pieces shall be conditioned for at least one week at $20 \pm 2^\circ\text{C}$ and $65 \pm 5\%$ relative humidity in accordance with ISO 554 : 1976. The timber material is conditioned when it attains constant mass. Constant mass is considered to be attained when the results of two successive weighings, carried out at an interval of six hours, do not differ by more than 0.1% of the mass of the timber material. For certain investigations other moisture conditioning may be appropriate, and shall be reported. For some hardwoods a much longer conditioning period may be necessary.

5.1.3.2.3 Assembly of test pieces

The size and geometry of the test pieces will depend upon the type of three-dimensional nailing plates and the property being measured, and shall be representative of the connection under practical conditions. The test pieces shall be assembled using the method normally used with the particular three-dimensional nailing plates.

Timber members for test pieces shall be cut so that the areas to which the three-dimensional nailing plates are fixed are free from knots, local grain disturbance, fissures and wane (except to the extent described in clause 5.1.0). Elsewhere, the members shall be free from characteristics which could lead to premature failure in the timber.

The fabrication of the test pieces shall reflect the gaps which can occur in practice (see clause 5.1.0).

5.1.3.3 Test procedure

5.1.3.3.1 Estimation of maximum load

The estimated maximum load $F_{\text{max,est}}$ for the type of joint to be tested shall be determined on the basis of experience, or by calculation or from preliminary tests, and shall be adjusted as required by the loading procedure.

5.1.3.3.2 Loading procedure

The loading procedure given in clause 8 of EN 26891 : 1991 shall be followed.

5.1.3.3.3 Maximum load

The load reached before or at a slip of 15 mm, shall be recorded as the maximum load for each specimen.

The compression capacity shall be taken as the highest load required to close the gap between the timber members.

Note: This will define the load-carrying capacity of the three-dimensional nailing plate, but not necessarily of the joint.

5.1.3.3.4 Deformation

Deformations shall be taken as the relative movement between the two timber members being joined (δm).

5.1.3.3.5 Test report

The test report shall include:

the timber species and grade, and the surface finish, density and moisture content of the timber

method for selecting timber density, by reference to EN 28970 : 1991

dimensions of the joints, size of the three-dimensional nailing plates, details of gaps between the members

specification of any fasteners used, eg nails, screws, by reference to an appropriate standard

conditioning of the timber and test pieces before and after fabrication

the loading procedure used, and a statement of any deviations from these procedures

product specification, including the dimensions, coating thickness, if appropriate, and specified mechanical properties (eg tensile strength, yield stress and elongation) of the metal used to manufacture the product

method of installation

individual test results of maximum load and any relevant information regarding adjustments, descriptions of the modes of failures, density of timber in which failure took place

initial slip and slip modulus according to EN 26891 : 1991, and load slip curve.

5.2 SAFETY IN CASE OF FIRE

The three-dimensional nailing plates covered by this ETAG are considered to satisfy the requirements for performance Class A1 of the characteristic reaction to fire, in accordance with the provisions of EC Decision 96/603/EC, as amended by EC Decision 2000/605/EC, without the need for testing on the basis of its listing in that Decision.

5.3 HYGIENE, HEALTH AND THE ENVIRONMENT

5.3.1 Release of dangerous substances

5.3.1.1 Presence of dangerous substances in the product

The applicant shall submit a written declaration and list of dangerous substances contained within the three-dimensional nailing plate in accordance with European and national regulations, indicating where these substances are relevant in the Member States of destination. If such dangerous substances are not present, this shall be stated.

5.3.1.2 Compliance with the application regulations

If the three-dimensional nailing plate contains dangerous substances as declared above, the ETA will provide the method(s) which has been used for demonstrating compliance with the applicable regulations in the Member States of destination, according to the dated EU database method(s) of content or release, as appropriate.

5.3.1.3 Application of the precautionary principle

An EOTA member is able to provide to other members, through the Secretary General, warning about substances which, according to Health Authorities of its country, are considered to be dangerous under sound scientific evidence, but are not yet regulated. Complete references about this evidence will be provided.

This information, once agreed upon, will be kept in an EOTA database, and will be transferred to the Commission Services.

The information contained in this EOTA database will also be communicated to any ETA applicant. On the basis of this information, a protocol of assessment of the product, regarding this substance, could be established on request of a manufacturer with the participation of the Approval Body which raised the issue.

5.4 SAFETY IN USE

Not relevant.

5.5 PROTECTION AGAINST NOISE

Not relevant.

5.6 ENERGY ECONOMY AND HEAT RETENTION

Not relevant.

5.7 ASPECTS OF DURABILITY, SERVICEABILITY AND IDENTIFICATION

To ensure an adequately durable structure, the following interrelated factors shall be considered following the principles of Eurocode 5:

use of the structure
required performance criteria
expected environmental conditions
composition, properties and performance of the materials
shape of members and the structural detailing
quality of the workmanship and the level of control
particular protective measures
likely maintenance during the intended life.

Note: The climatic conditions can generally be described by the service classes according to Eurocode 5.

5.7.1 Durability and serviceability

5.7.1.1 Resistance to corrosion and deterioration

The product specification (including associated ancillary components) shall be examined and an assessment or appropriate test and evaluation shall be carried out, to determine the thickness of corrosion protection or the material specification.

If a zinc coating is used its thickness shall be determined by:

- hot-dip galvanized coating to EN ISO 1461 : 1999 — using the methods described in the standard, preferably using the non-destructive magnetic method of EN ISO 2178 : 1995, or using the gravimetric method of EN ISO 1460 : 1994 as a reference method in case of dispute

- hot-dip zinc-coated sheet to EN 10142 : 2000 or EN 10147 : 2000 using the non-destructive magnetic method of EN ISO 2178 : 1995, or using the methods described in Annex A of the standard in the case of dispute
- electroplated zinc coating to ISO 2081 : 1986 — using the methods described in the standard, or using EN ISO 2177 : 1994 as a reference method in case of dispute.

If stainless steel is used it should be designated in accordance with EN 10088-1 : 1995.

5.7.1.2 Dimensional stability

Additional tests are not required for this property, which is covered during the assessment for mechanical resistance and stability.

5.7.2 **Methods of identification**

All components shall be clearly specified. Where possible, reference to harmonised European Standards shall be made.

The characteristics of the three-dimensional nailing plate with fasteners specified to be verified where appropriate, should, include:

- mechanical properties for the raw materials, eg tensile strength, yield strength, elongation, etc, for example in accordance with EN 10147 : 2000
- dimensional specification of raw materials for example in accordance with EN 10143 : 1993
- the type and thickness of any protective coating
- chemical composition of raw materials
- the mechanical properties of the fasteners
- dimensional specification of the fasteners
- geometry of the three-dimensional nailing plate.

6 ASSESSING AND JUDGING OF THE FITNESS OF PRODUCTS FOR AN INTENDED USE

6.0 GENERAL

This chapter details the performance requirements to be met (Chapter 4) in precise and measurable (as far as possible and proportional to the importance of the risk) or qualitative terms, related to the product and its intended use, using the outcome of the verification methods (Chapter 5).

Each performance requirement to be met for a given intended use in general, is assessed in terms of classes, use categories or numerical values. The ETA in general shall either indicate the result of these assessments or state 'No performance determined' (for countries/regions/buildings where no requirement is given in laws, regulations and administrative provisions). This statement does not mean that the three-dimensional nailing plates perform badly, but merely that this specific performance property has not been tested and assessed as it is not necessary within the context of the European Technical Approval.

The possible ways of expressing the results of the assessment of the mandatory performance requirements are shown in Table 6.1.

Table 6.1

ER	ETAG paragraph on product performance to be assessed	Category/Class/Numeric value
1	6.1.1 strength 6.1.2 stiffness 6.1.3 ductility in cyclic testing	Numeric value(s) numeric value(s) or No performance determined numerical value(s) or No performance determined
2	6.2 Reaction to fire	Class A1 according to EN 13501-1:2002 and EC Decision 96/603/EC, amended by EC Decision 2000/605/EC
3	6.3.1 dangerous substances	Indication of harmful materials by declaration, or No performance determined
4	NOT RELEVANT	
5	NOT RELEVANT	
6	NOT RELEVANT	
(1)	6.7.1 resistance to corrosion and deterioration	service class

(1) Aspects of durability, serviceability and identification.

6.1 MECHANICAL RESISTANCE AND STABILITY

Where properties are claimed for more than one direction of loading, each shall be given together with any interaction equation. Consideration should be given to the duration of load, the effects of reversal of load from long- and medium-term actions and alternating between tension and compression actions in the members.

Note: The value determined by clause 6.1.1 is the highest value the producer may declare as the characteristic value. It may be advisable to declare a lower value to avoid an unreasonable rejection.

6.1.1 Strength

The characteristic load-carrying capacity X_k or the modified load-carrying capacity $X_{k,mod}$ for a given load duration and service class defined in Eurocode 5 shall be given.

For assessment by 'calculation' and 'calculation assisted by testing' this shall be derived in accordance with the requirements of Eurocode 5 and for assessment by testing in accordance with prEN 14358, Structural timber, Calculation of characteristic 5-percentile values.

When deriving values from tests, account shall be taken of the density and moisture content of the timber test specimens, and deviations from the minimum specification for material properties of the three-dimensional nailing plate and ancillary components. See EOTA Technical Report *Method of testing three-dimensional nailing plates with examples*.

6.1.2 Stiffness

Where an initial slip and slip modulus are to be declared, they shall be determined as described in Eurocode 5. This relationship shall cover the serviceability limit state covering forces up to 40% of the ultimate force F_{ult} .

For assessment by tests these properties shall be determined in accordance with EN 26891 : 1991, clause 8.5:

Initial slip v_i
Slip modulus k_s (K_{ser} in Eurocode 5).

It is recommended that bolt holes should have a diameter not more than 2 mm larger than the bolt. This shall be considered in the load-slip relation.

6.1.3 Ductility in cyclic testing

In seismic zones, dissipative structural behaviour may be adopted in design if joints are able to deform plastically for at least three fully reversed cycles in cyclic testing according with EN 12512 : 2001 at a static ductility ratio of 4 for ductility class M structures and at a static ductility ratio of 6 for ductility class H ones, without more than a 20% reduction of their resistance, as laid down in clause 8.3.(3) of prEN 1998-1 : 2001.

6.2 SAFETY IN CASE OF FIRE

The three-dimensional nailing plates covered by this ETAG shall be classified according to EN 13501-1 : 2002. According to EC Decision 96/603/EC, amended by EC Decision 2000/605/EC, they are classified in class A1.

6.3 HYGIENE, HEALTH AND THE ENVIRONMENT

6.3.1 Release of dangerous substances

The three-dimensional nailing plate shall comply with all relevant European and national provisions applicable for the uses for which it is brought to the market. The attention of the applicant should be drawn to the fact that, for other uses or other Member States of destination, there may be other requirements which would have to be respected. For dangerous substances contained in the three-dimensional nailing plate but not covered by the ETA, the NPD option (no performance determined) is applicable.

Comment: The composition of ingot zinc (from which zinc coatings on steel are derived) is controlled under EN 1179 : 1995, in which a maximum limit for cadmium is imposed. This level

of cadmium as a trace component of a zinc coating is not restricted by European Directive 76/769/EEC on dangerous substances.

The product shall be clearly identified. Where possible, reference to European standards shall be made.

The chemical constitution and composition of the materials will be submitted by the applicant to the Approval Body which will observe strict rules of confidentiality. Under no circumstances will such information be disclosed to any other party.

The ETA is issued for the product with the chemical composition and other characteristics as deposited with the issuing Approval Body. Changes of materials, of composition or characteristics, should be notified immediately to the Approval Body, which will decide whether a new assessment will be necessary.

6.4 SAFETY IN USE

Not relevant

6.5 PROTECTION AGAINST NOISE

Not relevant.

6.6 ENERGY ECONOMY AND HEAT RETENTION

Not relevant.

6.7 ASPECTS OF DURABILITY, SERVICEABILITY AND IDENTIFICATION

6.7.1 Durability corrosion and deterioration

The materials specification or minimum corrosion protection for different service classes shall be in accordance with Eurocode 5. Alternative materials shall have equivalent properties/performance.

The edges of hot-dip zinc coated-steel sheet to EN 10142 : 2000 and EN 10147 : 2000, with a minimum coating weight of Z275 are galvanically protected by the zinc present on the faces of the sheet, and are known to have satisfactory long-term service in service class 2.

It is noted that standards for galvanized and electroplated coatings express mass/unit area of coatings with respect to the surface area, and standards for hot-dip coated sheet express mass/unit area with respect to the area of the sheet (ie the area of a sheet represents half the area of its surface).

Contact between three-dimensional nailing plate including the different materials used in the construction of the joint including the fasteners shall not result in corrosion occurring in the service classes being considered. Where appropriate, the product specification (including any ancillary components) will be examined to determine whether any risk of bimetallic corrosion exists (with reference to the electrochemical series), and any evidence of monitored atmospheric exposure tests to EN ISO 7441 : 1995 will be evaluated.

Contact between the three-dimensional nailing plate, including the fasteners and the timber species and preservative treatments proposed for use, shall not result in corrosion occurring in the service classes being considered. An assessment will be made of the risks of corrosion arising from any proposed preservative treatment for the timbers used with the product, or with any acidic timber species proposed for use.

6.7.2 Serviceability

The effects of deformations or deflections of the three-dimensional nailing plate which may affect the appearance or effective use of the structure or cause damage to finishes or non-structural elements shall be considered. Where appropriate, guidance should be given in the ETA in the form of an initial slip and a slip modulus (see clause 6.1.2).

6.7.2.1 Dimensional stability

The effects of dimensional changes on the structural elements being joined due to varying moisture content shall be considered by the determination of the strength and the stiffness of the joints.

6.7.3 Identification of the product

The three-dimensional nailing plate and any ancillary components shall be clearly identified by their geometry and material properties. Where possible, this shall be carried out by reference to European Standards.

Where the ancillary components are not covered by European Standards, they shall be precisely defined by reference to physical characteristics as indicated in this Guideline.

The determination of the product characteristics shall be based on testing or calculation in accordance with the appropriate CEN or EOTA test methods as far as they exist.

7 ASSUMPTIONS AND RECOMMENDATIONS UNDER WHICH THE FITNESS FOR USE OF THE THREE-DIMENSIONAL NAILING PLATES IS ASSESSED

7.0 GENERAL

This chapter sets out the assumptions and recommendations for design, installation and execution, packaging, transport and storage, use, maintenance and repair under which the assessment of the fitness for use according to the ETAG can be made (only when necessary and in so far as they have a bearing on the assessment or on the products).

7.1 DESIGN OF THE WORKS

The design of the works shall be in accordance with Eurocode 5 or with an appropriate structural design code.

7.2 PACKAGING, TRANSPORT AND STORAGE

For conventional metallic products, it is not necessary to consider special recommendations for packaging, transport and storage. In special cases it may be necessary for the approval body to draw attention to any necessary precaution in the ETA.

7.3 EXECUTION OF WORKS (INSTALLATION, ASSEMBLING, INCORPORATION, ETC, INCLUDING, IF NECESSARY, TEST METHODS FOR VERIFICATIONS ON SITE)

The ETA is issued under the assumption that the execution of the works shall be in accordance with the manufacturer's technical literature.

The quality and sufficiency of this technical literature shall be assessed against the recommendations of Eurocode 5, in particular concerning the aspects on the following checklist:

- number, location and type of fasteners
- condition and adequacy of supports and restraints
- specification of timber members, eg strength class, allowance for wane
- contact with preservative-treated timbers.
- permitted gap-size between members.

In accordance with the recommendations of Eurocode 5, bolts and screws should be re-tightened when the timber has reached equilibrium moisture content if this is necessary to ensure the load-carrying capacity or stiffness of the structure.

It is assumed that the manufacturing dimensions of the product are within such tolerances that the load-carrying capacity and stiffness of the connection can be maintained.

7.4 MAINTENANCE AND REPAIR

The assessment of the fitness for use is based on the assumption that no maintenance is required during the assumed intended working life.

Should repair prove necessary this is normally achieved by replacement.

SECTION THREE: ATTESTATION AND EVALUATION OF CONFORMITY (AC)

8 ATTESTATION AND EVALUATION OF CONFORMITY

8.1 EC DECISION

The system of attestation of conformity specified by the European Commission in Commission Decision 97/638/EC for fasteners for structural timber products is system 2+ described in Council Directive (89/106/EEC), Annex III, 2(ii), *First possibility* and is detailed as follows:

(a) Tasks for the manufacturer

- initial type-testing of the product
- factory production control.

Note: In the context of this Guideline, initial type-testing may be by testing and/or by calculation.

(b) Tasks for the approved body

Certification of factory production control on the basis of:

- initial inspection of factory and of factory production control
- continuous surveillance, assessment and approval of factory production control.

8.2 RESPONSIBILITIES

8.2.1 Tasks for the manufacturer

8.2.1.1 Factory production control

The manufacturer shall exercise permanent internal control of production. All the elements, requirements and provisions adopted by the manufacturer shall be documented in a systematic manner in the form of written policies and procedures. This production control system shall ensure that the product is in conformity with the European Technical Approval (ETA).

Manufacturers having an FPC system which complies with EN ISO 9000 : 2000 and EN ISO 9001 : 1994 or 2000, **and** which addresses the requirements of an ETA are recognised as satisfying the FPC requirements of the Directive.

8.2.1.2 Testing of samples taken at the factory – Prescribed Test Plan

The tests shall only be carried out on the final product or samples representative of the final product.

8.2.2 Tasks of the manufacturer or the Approved Body

8.2.2.1 Initial Type-Testing

Approval tests will have been conducted by the Approval Body or under its responsibility (which may include a proportion conducted by a laboratory or by the manufacturer, witnessed

by the Approval Body) in accordance with section 5 of this ETAG. The Approval Body will have assessed the results of these tests in accordance with section 6 of this ETAG, as part of the ETA issuing procedure.

These tests should be used for the purposes of Initial Type Testing⁽¹⁾.

This work should be taken over by the manufacturer for Declaration of Conformity purposes.

Note: In the context of this Guideline, initial type-testing may be by testing and/or by calculation.

(1) In this respect Approval Bodies shall be able to have open arrangements with relevant Approved Bodies to avoid duplication, respecting each others responsibilities.

8.2.3 Tasks for the Approved Body

8.2.3.1 Assessment of the factory production control system — initial inspection and continuous surveillance

Assessment of the factory production control system is the responsibility of the Approved Body.

An assessment must be carried out of each production unit to demonstrate that the factory production control is in conformity with the ETA and any subsidiary information. This assessment shall be based on an initial inspection of the factory.

Subsequently continuous surveillance of factory production control is necessary to ensure continuing conformity with the ETA.

8.2.3.2 Certification

The Approved Body shall issue the Certification of Factory Production Control.

8.3 DOCUMENTATION

The Approval Body issuing the ETA shall supply the information detailed below. The information given below, together with the requirements given in EC Guidance Paper B, will generally form the basis on which the factory production control (FPC) is assessed.

This information shall initially be prepared or collected by the Approval Body and shall be agreed with the manufacturer. The following gives guidance on the type of information required:

(1) The ETA

See section 9 of this Guideline.

The nature of any additional (confidential) information shall be declared in the ETA.

(2) Basic manufacturing process

The basic manufacturing process shall be described in sufficient detail to support the proposed FPC methods.

The different components of three-dimensional nailing plates, generally, are, manufactured using conventional techniques. Any critical process or treatment of the components which affects the performance shall be highlighted.

Note: welding is a critical treatment if the stress in the weld is larger than half the design stress.

(3) Product and materials specifications

These may include:

detailed drawings (including manufacturing tolerances)
incoming (raw) materials specifications and declarations
references to European and/or international standards or appropriate specifications
manufacturer's data sheets.

(4) Test plan (as part of FPC)

The manufacturer and the Approval Body issuing the ETA shall agree an FPC test plan.

An agreed FPC test plan is necessary as current standards relating to quality management systems (Guidance Paper B, EN ISO 9000:2000 and EN ISO 9001 : 2000) do not ensure that the product specification remains unchanged, and they cannot address the technical validity of the type or frequency of checks/tests.

The validity of the type and frequency of checks/tests conducted during production and on the final product shall be considered. This will include the checks conducted during manufacture on properties that cannot be inspected at a later stage and checks on the final product. These will normally include:

(4.1) Three-dimensional nailing plates

Checks on incoming materials

Supplier's certificate, eg mill certificate

Checks on process

Generally not applicable

Checks on finished products

Corrosion protection
Dimensions
Visual inspection, eg for cracks
Standard of welding, eg to the parts of EN 288

(4.2) Fasteners

The text in this Guideline on factory production control of fasteners is intended to be provisional, and may be superseded by the issue of the Harmonized Standard for fasteners under preparation by CEN TC 124 as prEN 14592.

Checks on incoming materials

Supplier's certificate mill certificate for steel materials, eg according to EN 10204 : 1991

Checks on process

Generally not applicable

Checks on finished products

Head diameter and thickness
Thread diameter (if appropriate)
Core diameter
Length
Washer (if any)
Thickness of corrosion protection (if any)
Mechanical tests, eg torsional strength of screws

(4.3) For coated steel parts

Cleaning/pretreatment process data
Coating process data
Mass and/or thickness of coating.

Where materials/components are not manufactured and tested by the supplier in accordance with agreed methods, then, where appropriate, they must be subject to suitable checks/tests by the manufacturer before acceptance.

(5) Prescribed test plan (testing of samples at the factory)

The manufacturer and the approval body issuing the ETA shall agree a prescribed test plan.

The characteristics to be addressed as described in the mandate are Mechanical resistance and Release of dangerous substances. These will be controlled at least twice per year by analysis/measurement/use of supplier's certificate, eg mill certificate of the relevant characteristics for the components from the following list:

composition
dimensions
physical properties
mechanical properties.

However, if the results of the surveillance inspections are satisfactory, the inspection interval can be reduced to once per year.

8.4 CE MARKING AND INFORMATION

The ETA shall indicate how the CE marking is to be placed, and the information to accompany it as given in the Construction Products Directive, and amplified by EC Guidance Paper D. Each three-dimensional nailing plate shall be marked with the CE marking and the number of the ETA, unless its size or surface makes this impossible.

SECTION FOUR: ETA CONTENT

9 THE ETA CONTENT

9.1 THE ETA CONTENT

9.1.1 Model ETA

The ETA content shall be in accordance with the Commission Decision 97/571/EC, dated 22 July 1997.

9.1.2 Performance

The technical part of the ETA shall contain information on the following items, in the order and with reference to the relevant Essential Requirements. For each of the listed items, the ETA shall either give the mentioned indication/classification/statement/ description or state that the verification/assessment of this item has not been carried out. For clarification the ETA may contain diagrams or illustrations of the product or its installation. The items are given here with reference to the relevant clause of this guidance.

9.1.2.1 Working life

An indication of the assumed working life is required [Section two, General Notes (d) Working Life (durability) and serviceability], however, this is dependent on the service class in which it is used. Therefore, the material specification and coating if any should also be given in a form compatible with Eurocode 5 and hence allow the designer to make an assessment.

9.1.2.2 Mechanical resistance, assumptions and specification

The technical part of the ETA should contain information on the following where appropriate:

- Characteristic load-carrying capacity for a given load duration and service class for each direction of loading considered (6.1.1)
- Initial slip and slip modulus for each direction of loading considered (6.1.2)
- Three-dimensional nailing plate specification, geometry (eg drawings and description), material specification and coating (if any) (6.7.3).
- Fastener specification (6.7.3)
- Fastener configuration to which the above relate (6.1.1)
- Timber specification to which the load-carrying capacity relates, eg strength class, presence of wane, sizes, surface finish (5.1.0)
- Assumptions regarding the support and/or restraint of the timber members being joined, eg simply supported, laterally restrained (5.1.0)
- Assumptions regarding preparation of timber members, eg pre-drilled holes, tolerance on hole diameter (5.1.0)
- Assumptions regarding permitted gap-size between members (5.1.0)
- Any special installation/maintenance provisions shall be highlighted, eg retightening of bolts (5.1.0).

9.1.2.3 Hygiene, health and the environment

The technical part of the ETA shall include a statement on the presence and concentration/emission rate/etc of dangerous substances or statement that dangerous materials are not present (see clause 6.3.1).

Note: In addition to the specific clauses relating to dangerous substances contained in this European Technical Approval, there may be other requirements applicable to the products falling within its scope (eg transposed European legislation and national laws, regulations and administrative provisions). To meet the provisions of the EU Construction Products Directive, these requirements need also to be complied with, when and where they apply. An informative database of European and national provisions on dangerous substances is available at the Construction website (see Annex B). This database should be used as a guide, but account must also be taken of any other relevant regulation or dangerous substance, which the database does not yet include.

The ETA is issued for the three-dimensional nailing plate with the chemical composition and other characteristics as deposited with the issuing Approval Body. Changes of materials, of composition or characteristics, should immediately be notified to the Approval Body which will decide whether a new assessment will be necessary.

9.2 ADDITIONAL INFORMATION

The ETA shall state that it is assumed that the design of the structural connection is in accordance with the relevant recommendations of Eurocode 5, or an appropriate structural timber design code, particularly in relation to the duration of load, the effects of reversal of load from long- and medium-term actions and alternating between tension and compression actions in the members.

The ETA shall state that the manufacturer's technical literature forms part of the ETA (see clause 7.3 of this Guideline).

Similarly, it shall be stated in the ETA whether or not any additional (possibly confidential) information shall be supplied to the Approved Body for the evaluation of conformity (see clause 8.3 of this Guideline).

ANNEX A

A COMMON TERMINOLOGY AND ABBREVIATIONS (DEFINITIONS, CLARIFICATIONS)

A.1 WORKS AND PRODUCTS

A.1.1 **Construction works (and parts of works)** (often simply referred to as 'works') (ID 1.3.1)

Everything that is constructed or results from construction operations and is fixed to the ground. (This covers both building and civil engineering works, and both structural and non-structural elements).

A.1.2 **Construction products** (often simply referred to as 'products') (ID 1.3.2)

Products manufactured for incorporation in a permanent manner in the works and placed as such on the market. (The term includes materials, elements and components of prefabricated systems or installations.)

A.1.3 **Incorporation** (of products in works) (ID 1.3.1)

Incorporation of a product in a permanent manner in the works means that:

- its removal reduces the performance capabilities of the works, and
- that the dismantling or the replacement of the product are operations involving construction activities.

A.1.4 **Intended use** (ID 1.3.4)

Role(s) that the product is intended to play in the fulfilment of the essential requirements.

A.1.5 **Execution** (ETAG-format)

Used in this document to cover all types of incorporation techniques, such as installation, assembling, incorporation, etc.

A.1.6 **System** (EOTA/TB guidance)

Part of the works realised by

- particular combination of a set of defined products, and
- particular design methods for the system, and/or
- particular execution procedures.

A.2 PERFORMANCES

A.2.1 **Fitness for intended use** (of products) (CPD 2.1)

Products have such characteristics that the works in which they are intended to be incorporated, assembled, applied or installed, can, if properly designed and built, satisfy the essential requirements.

A.2.2 **Serviceability** (of works)

Ability of the works to fulfil their intended use and in particular the essential requirements relevant for this use.

The products must be suitable for construction works which (as a whole and in their separate parts) are fit for their intended use, subject to normal maintenance, be satisfied for an economically reasonable working life. The requirements generally concern foreseeable actions (CPD Annex I, Preamble).

A.2.3 **Essential requirements** (for works)

Requirements applicable to works, which may influence the technical characteristics of a product, and are set out in terms of objectives in the CPD, Annex I (CPD, Art. 3.1).

A.2.4 **Performance** (of works, parts of works or products) (ID 1.3.7)

The quantitative expression (value, grade, class or level) of the behaviour of the works, parts of works or of the products, for an action to which it is subject or which it generates under the intended service conditions (works or parts of works) or intended use conditions (products).

A.2.5 **Actions** (on works or parts of the works) (ID 1.3.6)

Service conditions of the works which may affect the compliance of the works with the essential requirements of the Directive and which are brought about by agents (mechanical, chemical, biological, thermal or electromagnetic) acting on the works or parts of the works.

A.2.6 **Classes or levels** (for essential requirements and for related product performances) (ID 1.2.1)

A classification of product performance(s) expressed as a range of requirement levels of the works, determined in the IDs or according to the procedure provided for in Art. 20.2a of the CPD.

A.3 ETAG — FORMAT

A.3.1 **Requirements** (for works) (ETAG — format 4)

Expression and application, in more detail and in terms applicable to the scope of the Guideline, of the relevant requirements of the CPD (given concrete form in the IDs and further specified in the mandate, for works or parts of the works, taking into account the durability and serviceability of the works.

A.3.2 **Methods of verification** (for products) (ETAG — format 5)

Verification methods used to determine the performance of the products in relation to the requirements for the works (calculations, tests, engineering knowledge, evaluation of site experience, etc).

A.3.3 **Specifications** (for products) (ETAG — format 6)

Transposition of the requirements into precise and measurable (as far as possible and proportional to the importance of the risk) or qualitative terms, related to the products and their intended use.

A.4 WORKING LIFE

A.4.1 **Working life** (of works or parts of the works) [ID 1.3.5(1)]

The period of time during which the performance will be maintained at a level compatible with the fulfilment of the essential requirements.

A.4.2 **Working life** (of products)

Period of time during which the performances of the product are maintained — under the corresponding service conditions — at a level compatible with the intended use conditions.

A.4.3 **Economically reasonable working life** [ID 1.3.5(2)]

Working life which takes into account all relevant aspects, such as costs of design, construction and use, costs arising from hindrance of use, risks and consequences of failure of the works during its working life and cost of insurance covering these risks, planned partial renewal, costs of inspections, maintenance, care and repair, costs of operation and administration, of disposal and environmental aspects.

A.4.4 **Maintenance** (of works) [ID 1.3.3(1)]

A set of preventive and other measures applied to the works to enable the works to fulfil all its functions during its working life. These measures include cleaning, servicing, repainting, repairing, replacing parts of the works where needed, etc.

A.4.5 **Normal maintenance** (of works) [ID 1.3.3(2)]

Maintenance, normally including inspections, occurring at a time when the cost of the intervention which has to be made is not disproportionate to the value of the part of the work concerned, consequential costs (eg exploitation) being taken into account.

A.4.6 **Durability** (of products)

Ability of the product to contribute to the working life of the work by maintaining its performances, under the corresponding service conditions, at a level compatible with the fulfilment of the essential requirements by the works.

A.5 **Conformity**

A.5.1 **Attestation of conformity** (of products)

Provisions and procedures as laid down in the CPD and fixed according to the directive, aiming to ensure that, with acceptable probability, the specified performance of the product is achieved by the ongoing production.

A.5.2 **Identification** (of a product)

Product characteristics and methods of their verification, allowing to compare a given product with the one that is described in the technical specification.

A.6 **APPROVAL AND APPROVED BODIES**

A.6.1 **Approval Body**

Body notified in accordance with Article 10 of the CPD, by an EU Member State or by an EFTA State (contracting party to the EEA Agreement), to issue European Technical Approvals in (a) specific construction product area(s). All such bodies are required to be members of the European Organisation for Technical Approvals (EOTA), set up in accordance with Annex II.2 of the CPD.

A.6.2 **Approved Body⁽¹⁾**

Body nominated in accordance with Article 18 of the CPD, by an EU Member State or by an EFTA State (contracting party to the EEA Agreement), to perform specific tasks in the framework of the Attestation of Conformity decision for specific construction products

(certification, inspection or testing). All such bodies are automatically members of the Group of Notified Bodies.

(1) also known as Notified Body.

ABBREVIATIONS

Concerning the Construction Products Directive

AC:	Attestation of Conformity
CEC:	Commission of the European Communities
CEN:	Comité Européen de Normalisation (European Committee for Standardization)
CPD:	Construction Products Directive
EC:	European Communities
EFTA:	European Free Trade Association
E	European Standards
FPC:	Factory Production Control
ID:	Interpretative Documents of the CPD
ISO:	International Standardisation Organisation
SCC:	Standing Committee on Construction of the EC.

Concerning approval

EOTA:	European Organisation for Technical Approvals
ETA:	European Technical Approval
ETAG:	European Technical Approval Guideline
RILEM	TC 169 MTE: Réunion Internationale des Laboratoires et de Recherches sur les Matériaux et les constructions/International Union of Testing and Research Laboratories for Materials and Structures Technical Committee 169 – Test methods for load transferring Metalwork used in Timber Engineering
TB:	EOTA Technical Board
UEAtc:	Union Européenne pour l'Agrément technique dans la construction (European Union of Agreement).

General

TC	Technical Committee
WG:	Working Group.

ANNEX B

List of documents

Construct 99/339 -Rev 1	Mandate to EOTA concerning the execution of harmonisation work for an ETA Guideline on three-dimensional nailing plates
Mandate M112	to CEN/CENELEC concerning the execution of standardisation work for harmonised standards on structural timber products and ancillaries
Mandate M116	to CEN/CENELEC concerning the execution of standardisation work for harmonised standards on masonry and related products
Commission Decision 96/603/EC of 4 October 1996, Official Journal L267, 19.10.96 p23 amended by Commission Decision 2000/605/EC	
Council Directive 89/106/EEC (CPD) of 21 December 1988, on the approximation of laws, regulations and administrative provisions of the Member States relating to construction products. Official Journal L40, 11.2.89 p 12-26	
prEN 1995-1-1	Eurocode 5: Design of timber structures. Part 1-1: General – Common rules and rules for buildings.
EC Guidance Paper L	Application and use of Eurocodes.
Council Directive 76/769/EEC on the approximation of the laws, regulations and administrative provisions of the Member States relating to restrictions on the marketing and use of certain dangerous substances and preparations.	
	Official Journal No L 262, 27.9.76, p 201 and subsequent amendments
EOTA Guidance Document N° 004	The provision of data for assessment leading to ETA
EN 338 : 1995	Structural timber. Strength classes
EN 10088-1 : 1995	List of stainless steels
EN 10088-2 : 1995	Stainless steels. Technical delivery conditions for sheet/plate and strip for general purposes.
EN 10142 : 2000	Continuously hot-dip zinc coated low carbon steels strip and sheet for cold forming. Technical delivery conditions.
EN 10147 : 2000	Specification for continuously hot-dip zinc coated structural steel sheet and strip. Technical delivery conditions.
prEN 1993-1-1	Eurocode 3. Design of steel structures. Part 1-1: General rules
prEN 1993-1-3	Eurocode 3. Design of steel structures. Part 1-3: General rules. Supplementary rules for cold-formed thin gauge members and sheeting.
prEN 1998-1	Eurocode 8. Design of structures for earthquake resistance. Part 1: General rules, seismic actions and rules for buildings.
EN 26891 : 1991	Timber structures. Joints made with mechanical fasteners. General principles for the determination of strength and deformation characteristics

EOTA Technical Report	Principles for the static calculation of connections made with Three-Dimensional Nailing Plates, with examples
EOTA Technical Report	Method of Testing Three-Dimensional Nailing Plates, with examples
EOTA Technical Report	Worked example calculation of characteristic load-carrying capacities of 90° angle bracket with a rib
EN 28970 : 1991	Timber structures. Testing of joints made with mechanical fasteners. Requirements for wood density
EN 10002-1 : 1990	Tensile testing of metallic materials. Method of test at ambient temperature
EN 1380 : 1999	Timber structures. Test methods. Loadbearing nailed joints
EN 1382 : 1999	Timber structures. Test methods. Withdrawal capacity of timber fasteners
EN 1383 : 1999	Timber structures. Test methods. Pull-through resistance of timber fasteners
EN 12512 : 2001	Timber structures. Test methods. Cyclic testing of joints made with mechanical fasteners
EN 288	Specification and approval of welding procedures for metallic materials
prEN 14592	Timber structures. Fasteners. Requirements
ISO 3130 : 21975	Wood. Determination of moisture content for physical and mechanical tests
ISO 3131 : 1975	Wood. Determination of density for physical and mechanical tests
ISO 554 : 1976	Standard atmospheres for conditioning and/or testing. Specifications
EN ISO 1461 : 1999	Hot dip galvanized coatings on fabricated iron and steel articles. Specification and test methods
EN ISO 2178 : 1995	Non-magnetic coatings on magnetic substances. Measurements of coating thickness. Magnetic method
EN ISO 1460 : 1995	Metallic coatings. Hot dip galvanized coatings on ferrous materials. Gravimetric determination of the mass per unit area
ISO 2081 : 1986	Metallic coatings. Electroplated coatings of zinc on iron or steel
EN ISO 2177 : 1994	Metallic coatings. Measurement of coating thickness. Coulometric method by anodic dissolution
EN 10143 : 1993	Continuously hot-dip metal coated steel sheet and strip. Tolerances on dimensions and shape
EN 13501-1 : 2002	Fire classification of construction products and building elements - Part 1: Classification using test data from reaction to fire tests
EN 1179 : 1996	Specifications for zinc and zinc alloys. Primary zinc
EN ISO 7441 : 1995	Corrosion of metals and alloys. Determination of bimetallic corrosion in outdoor exposure corrosion tests
Commission Decision 97/638/EC of 19 September 1997 on the procedure for attesting the conformity of construction products pursuant to Article 20(2) of Council Directive 89/106/EEC as regards fasteners for structural timber	

EN ISO 9000 : 2000 Quality management systems. Fundamentals and vocabulary

EN ISO 9001 : 2000 Quality management systems. Requirements

EC Guidance Paper B The definition of factory production control in technical specifications for construction products

EN 10204 : 1991 Metallic products. Types of inspection documents

EC Guidance Paper D CE marking under the Construction Products Directive

Commission Decision 22 July 1997, Official Journal L 236 27.8.97

prEN 14358 Structural timber – Calculation of characteristic 5-percentile values

EU database on dangerous substances in construction products:
<http://europa.eu.int/comm/enterprise/construction/internal/hygiene.htm>